

# CoroBore™ 825

Fijnkottergereedschap voor uiterst nauwkeurig kotteren

## Toepassing

- Conventioneel fijnkotteren
- Trekkend kotteren

## ISO toepassingsgebied



## Voordelen en kenmerken

- Flexibele oplossingen voor aansluiting op elke machinekoppeling; kies tussen Coromant Capto- en EH modulaire koppelingen
- Realiseer benodigde uitsteeklengte, zelfs bij kleine diameters met het EH modulaire systeem
- Betrouwbaar systeem met robuuste koppelingen tussen kop en cassette, voor stabiel en trillingsvrij kotteren
- CoroBore 825 heeft een accurate handmatige snijkantinstelling met een resolutie van 0,01 mm op de diameter
- Nauwe gattoleranties IT6
- Leverbaar als gedempt gereedschap voor trillingsvrij kotteren, zelfs bij lange uitsteeklengtes
- Koelmiddel door het gereedschap



[www.sandvik.coromant.com/corobore825](http://www.sandvik.coromant.com/corobore825)

## Klemhouders

Koppelingen:

- Coromant Capto®
- Coromant EH
- Cilindrische schacht

## Wisselplaten

Standaardwisselplaten met specifieke geometrieën en hardmetaalsoorten voor alle materialen

- CoroTurn® 107
- CoroTurn® 111 (niet beschikbaar als sets)



Stelt de diameter in met een nauwkeurigheid van 0,002 mm met een noniusschaal. Bij een omwenteling van 360° verandert de diameter met 0,5 mm.



Met een Silent Tools™ demper dicht bij de snijkant en een fijnkotterkop in aluminium met gereduceerde lengte, kunnen betere prestaties en een verhoogde productiviteit worden bereikt.



Tevens leverbaar als lichtgewicht gereedschappen. Kotteren van grote diameters met betere stabiliteit zonder het gereedschap te verzwaren.

# CoroBore® 826

Fijnkottergereedschap voor uiterst nauwkeurig kotteren

## Toepassing

- Fijnkotteren met hoge nauwkeurigheid

## ISO toepassingsgebied



## Voordelen en kenmerken

- Uitstekende spaanbeheersing dankzij op snijkant gericht precisiekoelmiddel tot wel 70 bar
- Koelmiddel door het gereedschap en de cassette
- Gemakkelijke instelling van gereedschap dankzij stapsgewijze klikfunctie
- Betrouwbaar systeem met robuuste koppelingen tussen kop en cassette, voor stabiel en trillingsvrij kotteren
- Nauwkeurige gattoleranties tot IT6
- CoroBore® 826 high precision stelt de snijkant in met een resolutie van 2 micrometer op de diameter



[www.sandvik.coromant.com/corobore826](http://www.sandvik.coromant.com/corobore826)

## Klemhouders

Koppelingen:  
- Coromant Capto®

## Wisselplaten

Standaardwisselplaten met specifieke hardmetaalsoorten en geometrieën voor alle materialen  
- CoroTurn® 107



Elke klik past diameter met 0,002 mm aan. Een omwenteling van 360° wijzigt de diameter met 0,1 mm. Totale diameterverandering op fijnkotterkop 1,1-1,3 mm.

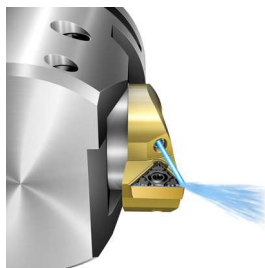

Koelmiddelspuitmond met hoge precisie voor nauwkeurige koelmiddelstroom naar snijkant



Vergroot het diameterbereik door cassette-sets te gebruiken! Zie pagina K84

# CoroBore® 825 fijnkottergereedschap

Coromant Capto® - inwendige koelmiddeltoevoer



- TCMT, TCMX, TCGT, TCGX, TCEX
- TCMW

KAPR  
DSGN

92°  
1

92°  
2

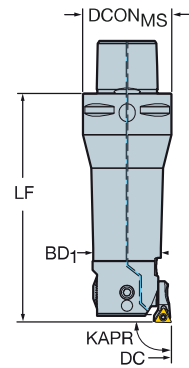
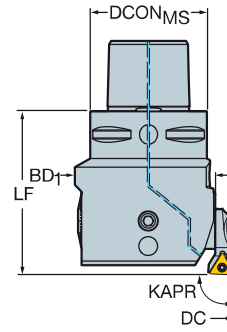
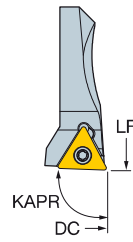

Afmetingen, mm

DCN	DCX		CZC <sub>MS</sub>	CNSC	DSGN	Bestelnummer	DCON <sub>MS</sub>	ADJLX <sub>RDL</sub>	ULDR	LF	BD <sub>1</sub>			CICT	MIID
19,00	23,00	06	C3	3	2	825-23TC06-C3	32,00	2,00	3,00	89,00	18,00	70	0,430	1	TCMT 06 T1 02
23,00	29,00	06	C3	3	2	825-29TC06-C3	32,00	3,00	2,00	76,00	20,00	70	0,414	1	TCMT 06 T1 02
23,00	29,00	06	C4	3	2	825-29TC06-C4	40,00	3,00	2,00	85,00	20,00	70	0,897	1	TCMT 06 T1 02
28,00	36,00	06	C3	3	2	825-36TC06-C3	32,00	4,00	2,00	83,00	25,00	70	0,692	1	TCMT 06 T1 02
28,00	36,00	06	C4	3	2	825-36TC06-C4	40,00	4,00	2,00	95,00	25,00	70	0,992	1	TCMT 06 T1 02
35,00	45,00	09	C3	3	1	825-45TC09-C3	32,00	5,00		48,00	32,00	70	0,641	1	TCMT 09 02 04
35,00	45,00	09	C4	3	2	825-45TC09-C4	40,00	5,00	1,50	83,00	32,00	70	1,007	1	TCMT 09 02 04
44,00	56,00	09	C4	3	1	825-56TC09-C4	40,00	6,00		56,00	40,00	70	0,874	1	TCMT 09 02 04
44,00	56,00	09	C5	3	2	825-56TC09-C5	50,00	6,00	1,50	98,00	40,00	70	1,600	1	TCMT 09 02 04
55,00	70,00	11	C5	3	1	825-70TC11-C5	50,00	7,50		66,00	50,00	70	1,430	1	TCMT 11 03 04
55,00	70,00	11	C6	3	2	825-70TC11-C6	63,00	7,50	1,50	120,00	50,00	70	2,620	1	TCMT 11 03 04
69,00	87,00	11	C5	3	1	825-87TC11-C5	50,00	9,00		70,00	63,00	70	1,930	1	TCMT 11 03 04
69,00	87,00	11	C6	3	1	825-87TC11-C6	63,00	9,00		78,00	63,00	70	2,360	1	TCMT 11 03 04
86,00	107,00	11	C5	3	1	825-107TC11-C5	50,00	10,50		76,00	80,00	70	2,240	1	TCMT 11 03 04
86,00	107,00	11	C6	3	1	825-107TC11-C6	63,00	10,50		90,00	80,00	70	3,180	1	TCMT 11 03 04
106,00	137,00	11	C6	3	1	825-137TC11-C6	63,00	15,50		90,00	100,00	70	3,792	1	TCMT 11 03 04
106,00	137,00	11	C8	3	1	825-137TC11-C8	80,00	15,50		100,00	100,00	70	5,045	1	TCMT 11 03 04
136,00	167,00	11	C6	3	1	825-167TC11-C6	63,00	15,50		90,00	130,00	70	4,430	1	TCMT 11 03 04
136,00	167,00	11	C8	3	1	825-167TC11-C8	80,00	15,50		100,00	130,00	70	5,570	1	TCMT 11 03 04

Diameters gelden voor frontaal kotteren.

Voor meer informatie over trekkend kotteren raadpleegt u pagina K92

Voor meer informatie over het gebruik van slede-uitbreidingen raadpleegt u pagina K89

Ga voor kottergereedschappen, toebehoren en onderdelen naar [www.sandvik.coromant.com](http://www.sandvik.coromant.com)

Zie voor wisselplaten de Draaigereedschappencatalogus

Voor alle DSGN 2; LU = DC\*ULDR



K89



# CoroBore® 825 fijnkottergereedschap

Cilindrische schacht - interne koelmiddeltoevoer



- TCMT, TCMX, TCGT, TCGX, TCEX
- TCMW

KAPR

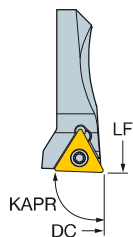

92°

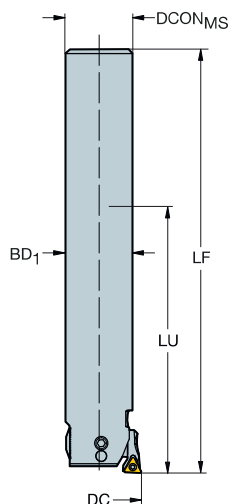

K

Afmetingen, mm

DCN	DCX		CZC <sub>MS</sub>	CNSC	Bestelnummer	DCON <sub>MS</sub>	ADJLX <sub>RDL</sub>	LU	LF	BD <sub>1</sub>			CICT	MIID
19,00	23,00	06	18	1	825-23TC06-A18	18,00	2,00	77,00	128,00	18,00	70	0,731	1	TCMT 06 T1 02
23,00	29,00	06	20	1	825-29TC06-A20	20,00	3,00	81,00	132,00	20,00	70	0,606	1	TCMT 06 T1 02
28,00	36,00	06	25	1	825-36TC06-A25	25,00	4,00	101,00	158,00	25,00	70	0,951	1	TCMT 06 T1 02

Diameters gelden voor frontaal kotteren.

Voor meer informatie over trekkend kotteren raadpleegt u pagina K92

Voor meer informatie over het gebruik van slede-uitbreidingen raadpleegt u pagina K89

Ga voor kottergereedschappen, toebehoren en onderdelen naar [www.sandvik.coromant.com](http://www.sandvik.coromant.com)

Zie voor wisselplaten de Draaigereedschappencatalogus

L

M



N



# CoroBore® 825 fijnkottergereedschap

Coromant EH-koppeling - interne koelmiddeltoevoer





-  TCMT, TCMX, TCGT, TCGX, TCEX
-  TCMW

KAPR

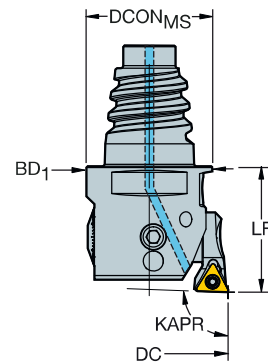
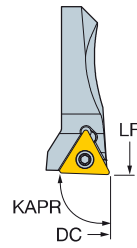
92°



Afmetingen, mm

DCN	DCX		CZC <sub>MS</sub>	CNSC	Bestelnummer	DCON <sub>MS</sub>	ADJLX <sub>RDL</sub>	LF	BD <sub>1</sub>			CICT	MIID
19,00	23,00	06	E16	1	825-23TC06-EH16	15,50	2,00	25,00	18,00	70	0,500	1	TCMT 06 T1 02
23,00	29,00	06	E20	1	825-29TC06-EH20	19,30	3,00	25,00	20,00	70	0,600	1	TCMT 06 T1 02
28,00	36,00	06	E25	1	825-36TC06-EH25	24,20	4,00	25,00	25,00	70	0,687	1	TCMT 06 T1 02

Diameters gelden voor frontaal kotteren.

Voor meer informatie over trekkend kotteren raadpleegt u pagina K92

Voor meer informatie over het gebruik van slede-uitbreidingen raadpleegt u pagina K89

Ga voor kottergereedschappen, toebehoren en onderdelen naar [www.sandvik.coromant.com](http://www.sandvik.coromant.com)

Zie voor wisselplaten de Draaigereedschappencatalogus



L2



N23



N15



K89

# CoroBore® 826 fijnkottergereedschap

Coromant Capto® - Precisie koelmiddeltoevoer

KAPR

92°

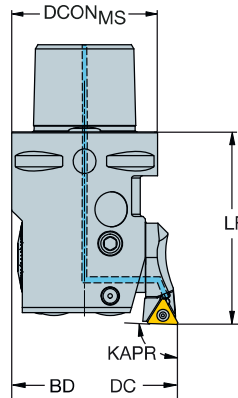

- TCMT, TCMX, TCGT, TCGX, TCEX
- TCMW

						Afmetingen, mm								
DCN	DCX		CZC <sub>MS</sub>	CNSC	Bestelnummer	DCON <sub>MS</sub>	ADJLX <sub>RDL</sub>	LF	BD <sub>1</sub>			CICT	MIID	
35,45	36,55	09	C3	3	826-36TC09-C3HP	32,00	0,55	48,00	32,00	70	0,566	1	TCMT 09 02 04	
36,45	37,55	09	C3	3	826-37TC09-C3HP	32,00	0,55	48,00	32,00	70	0,565	1	TCMT 09 02 04	
37,45	38,55	09	C3	3	826-38TC09-C3HP	32,00	0,55	48,00	32,00	70	0,631	1	TCMT 09 02 04	
38,45	39,55	09	C3	3	826-39TC09-C3HP	32,00	0,55	48,00	32,00	70	0,640	1	TCMT 09 02 04	
39,45	40,55	09	C3	3	826-40TC09-C3HP	32,00	0,55	48,00	32,00	70	0,647	1	TCMT 09 02 04	
40,45	41,55	09	C3	3	826-41TC09-C3HP	32,00	0,55	48,00	32,00	70	0,290	1	TCMT 09 02 04	
41,45	42,55	09	C3	3	826-42TC09-C3HP	32,00	0,55	48,00	32,00	70	0,290	1	TCMT 09 02 04	
42,45	43,55	09	C3	3	826-43TC09-C3HP	32,00	0,55	48,00	32,00	70	0,290	1	TCMT 09 02 04	
43,45	44,55	09	C3	3	826-44TC09-C3HP	32,00	0,55	48,00	32,00	70	0,290	1	TCMT 09 02 04	
44,45	45,55	09	C4	3	826-45TC09-C4HP	40,00	0,55	56,00	40,00	70	0,591	1	TCMT 09 02 04	
45,45	46,55	09	C4	3	826-46TC09-C4HP	40,00	0,55	56,00	40,00	70	0,570	1	TCMT 09 02 04	
46,45	47,55	09	C4	3	826-47TC09-C4HP	40,00	0,55	56,00	40,00	70	1,104	1	TCMT 09 02 04	
47,45	48,55	09	C4	3	826-48TC09-C4HP	40,00	0,55	56,00	40,00	70	0,570	1	TCMT 09 02 04	
48,45	49,55	09	C4	3	826-49TC09-C4HP	40,00	0,55	56,00	40,00	70	0,570	1	TCMT 09 02 04	
49,45	50,55	09	C4	3	826-50TC09-C4HP	40,00	0,55	56,00	40,00	70	0,918	1	TCMT 09 02 04	
50,45	51,55	09	C4	3	826-51TC09-C4HP	40,00	0,55	56,00	40,00	70	0,570	1	TCMT 09 02 04	
51,45	52,55	09	C4	3	826-52TC09-C4HP	40,00	0,55	56,00	40,00	70	0,940	1	TCMT 09 02 04	
52,45	53,55	09	C4	3	826-53TC09-C4HP	40,00	0,55	56,00	40,00	70	0,570	1	TCMT 09 02 04	
53,45	54,55	09	C4	3	826-54TC09-C4HP	40,00	0,55	56,00	40,00	70	0,570	1	TCMT 09 02 04	
54,45	55,55	09	C4	3	826-55TC09-C4HP	40,00	0,55	56,00	40,00	70	0,570	1	TCMT 09 02 04	
55,35	56,65	11	C5	3	826-56TC11-C5HP	50,00	0,65	66,00	50,00	70	1,397	1	TCMT 11 03 04	
56,35	57,65	11	C5	3	826-57TC11-C5HP	50,00	0,65	66,00	50,00	70	1,455	1	TCMT 11 03 04	
57,35	58,65	11	C5	3	826-58TC11-C5HP	50,00	0,65	66,00	50,00	70	1,414	1	TCMT 11 03 04	
58,35	59,65	11	C5	3	826-59TC11-C5HP	50,00	0,65	66,00	50,00	70	1,070	1	TCMT 11 03 04	
59,35	60,65	11	C5	3	826-60TC11-C5HP	50,00	0,65	66,00	50,00	70	1,466	1	TCMT 11 03 04	
60,35	61,65	11	C5	3	826-61TC11-C5HP	50,00	0,65	66,00	50,00	70	1,070	1	TCMT 11 03 04	
61,35	62,65	11	C5	3	826-62TC11-C5HP	50,00	0,65	66,00	50,00	70	1,070	1	TCMT 11 03 04	
62,35	63,65	11	C5	3	826-63TC11-C5HP	50,00	0,65	66,00	50,00	70	1,426	1	TCMT 11 03 04	
63,35	64,65	11	C5	3	826-64TC11-C5HP	50,00	0,65	66,00	50,00	70	1,503	1	TCMT 11 03 04	
64,35	65,65	11	C5	3	826-65TC11-C5HP	50,00	0,65	66,00	50,00	70	1,520	1	TCMT 11 03 04	
65,35	66,65	11	C5	3	826-66TC11-C5HP	50,00	0,65	66,00	50,00	70	1,070	1	TCMT 11 03 04	
66,35	67,65	11	C5	3	826-67TC11-C5HP	50,00	0,65	66,00	50,00	70	1,070	1	TCMT 11 03 04	
67,35	68,65	11	C5	3	826-68TC11-C5HP	50,00	0,65	66,00	50,00	70	1,070	1	TCMT 11 03 04	
68,35	69,65	11	C5	3	826-69TC11-C5HP	50,00	0,65	66,00	50,00	70	1,070	1	TCMT 11 03 04	
69,35	70,65	11	C5	3	826-70TC11-C5HP	50,00	0,65	66,00	50,00	70	1,455	1	TCMT 11 03 04	
70,35	71,65	11	C5	3	826-71TC11-C5HP	50,00	0,65	66,00	50,00	70	1,070	1	TCMT 11 03 04	
71,35	72,65	11	C5	3	826-72TC11-C5HP	50,00	0,65	66,00	50,00	70	1,070	1	TCMT 11 03 04	
72,35	73,65	11	C5	3	826-73TC11-C5HP	50,00	0,65	66,00	50,00	70	1,557	1	TCMT 11 03 04	
73,35	74,65	11	C6	3	826-74TC11-C6HP	63,00	0,65	78,00	63,00	70	1,940	1	TCMT 11 03 04	
74,35	75,65	11	C6	3	826-75TC11-C6HP	63,00	0,65	78,00	63,00	70	1,940	1	TCMT 11 03 04	
75,35	76,65	11	C6	3	826-76TC11-C6HP	63,00	0,65	78,00	63,00	70	2,400	1	TCMT 11 03 04	
76,35	77,65	11	C6	3	826-77TC11-C6HP	63,00	0,65	78,00	63,00	70	1,940	1	TCMT 11 03 04	
77,35	78,65	11	C6	3	826-78TC11-C6HP	63,00	0,65	78,00	63,00	70	1,940	1	TCMT 11 03 04	
78,35	79,65	11	C6	3	826-79TC11-C6HP	63,00	0,65	78,00	63,00	70	1,940	1	TCMT 11 03 04	

Ga voor kottergereedschappen, toebehoren en onderdelen naar [www.sandvik.coromant.com](http://www.sandvik.coromant.com)  
Zie voor wisselplaten de Draaigereedschappencatalogus



# CoroBore® 826 fijnkottergereedschap

Coromant Capto® - Precisie koelmiddeltoevoer

KAPR

92°

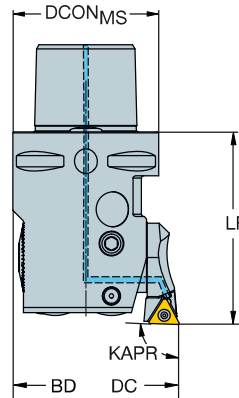

- TCMT, TCMX, TCGT, TCGX, TCEX
- TCMW

					Afmetingen, mm								
DCN	DCX		CZC <sub>MIS</sub>	CNSC	Bestelnummer	DCON <sub>MS</sub>	ADJLX <sub>RDL</sub>	LF	BD <sub>1</sub>			CICT	MIID
79.35	80.65	11	C6	3	826-80TC11-C6HP	63.00	0.65	78.00	63.00	70	1,940	1	TCMT 11 03 04
80.35	81.65	11	C6	3	826-81TC11-C6HP	63.00	0.65	78.00	63.00	70	1,940	1	TCMT 11 03 04
81.35	82.65	11	C6	3	826-82TC11-C6HP	63.00	0.65	78.00	63.00	70	1,940	1	TCMT 11 03 04
82.35	83.65	11	C6	3	826-83TC11-C6HP	63.00	0.65	78.00	63.00	70	1,940	1	TCMT 11 03 04
83.35	84.65	11	C6	3	826-84TC11-C6HP	63.00	0.65	78.00	63.00	70	1,940	1	TCMT 11 03 04
84.35	85.65	11	C6	3	826-85TC11-C6HP	63.00	0.65	78.00	63.00	70	1,940	1	TCMT 11 03 04
85.35	86.65	11	C6	3	826-86TC11-C6HP	63.00	0.65	78.00	63.00	70	1,940	1	TCMT 11 03 04
86.35	87.65	11	C6	3	826-87TC11-C6HP	63.00	0.65	78.00	63.00	70	1,940	1	TCMT 11 03 04
87.35	88.65	11	C6	3	826-88TC11-C6HP	63.00	0.65	78.00	63.00	70	1,940	1	TCMT 11 03 04
88.35	89.65	11	C6	3	826-89TC11-C6HP	63.00	0.65	78.00	63.00	70	1,940	1	TCMT 11 03 04
89.35	90.65	11	C6	3	826-90TC11-C6HP	63.00	0.65	78.00	63.00	70	1,940	1	TCMT 11 03 04
90.35	91.65	11	C6	3	826-91TC11-C6HP	63.00	0.65	78.00	63.00	70	1,940	1	TCMT 11 03 04

Ga voor kottergereedschappen, toebehoren en onderdelen naar [www.sandvik.coromant.com](http://www.sandvik.coromant.com)  
 Zie voor wisselplaten de Draaigereedschappencatalogus



# CoroBore® 826 fijnkottergereedschap

Coromant Capto® - inwendige koelmiddeltoevoer

KAPR

92°

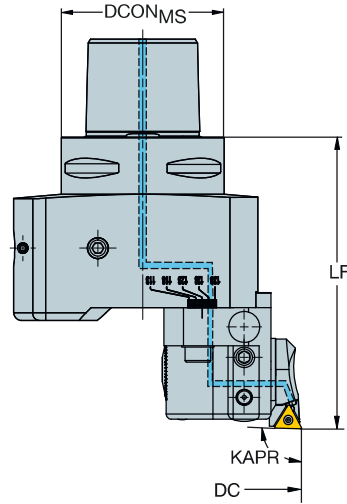
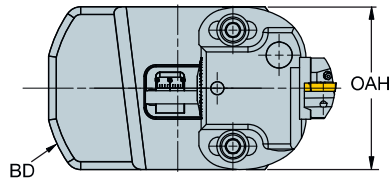

- TCMT, TCMX, TCGT, TCGX, TCEX
- TCMW

					Afmetingen, mm									
DCN	DCX		CZC <sub>MS</sub>	CNSC	Bestelnummer	DCON <sub>MS</sub>	ADJLX <sub>EDL</sub>	LF	OAH	BD <sub>1</sub>			CICT	MIID
91,35	112,65	11	C6	3	826-112TC11-C6HP	63,00	10,65	113,00	63,00	85,00	70	3,215	1	TCMT 11 03 04
112,35	133,65	11	C6	3	826-133TC11-C6HP	63,00	10,65	113,00	63,00	105,00	70	3,645	1	TCMT 11 03 04
133,35	154,65	11	C6	3	826-154TC11-C6HP	63,00	10,65	113,00	63,00	125,00	70	3,940	1	TCMT 11 03 04

Ga voor kottergereedschappen, toebehoren en onderdelen naar [www.sandvik.coromant.com](http://www.sandvik.coromant.com)  
 Zie voor wisselplaten de Draaigereedschappencatalogus



L2



N23



N15



K89



# CoroBore® 825 lichtgewicht fijnkottergereedschap

Coromant Capto® - inwendige koelmiddeltoevoer



KAPR

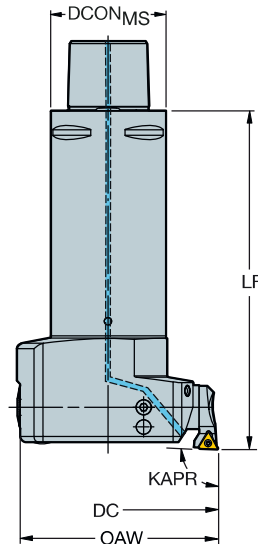
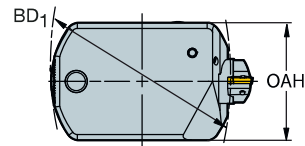
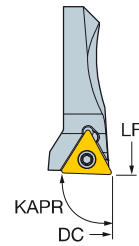

92°



TCMT, TCMX,  
TCGT, TCGX  
TCEX

TCMW

Afmetingen, mm

DCN	DCX		CZC <sub>MS</sub>	CNSC	Bestelnummer	DCON <sub>MS</sub>	ADJLX <sub>FDL</sub>	LF	OAH	BD <sub>1</sub>			CICT	MIID
69.00	87.00	11	C5	3	825L-87TC11-C5	50.00	9.00	150.00	51.00	63.00	70	2.150	1	TCMT 11 03 04
86.00	107.00	11	C5	3	825L-107TC11-C5	50.00	10.50	156.00	51.00	80.00	70	2.230	1	TCMT 11 03 04
106.00	137.00	11	C6	3	825L-137TC11-C6	63.00	15.50	190.00	64.00	100.00	70	3.970	1	TCMT 11 03 04
106.00	137.00	11	C8	3	825L-137TC11-C8	80.00	15.50	200.00	80.00	100.00	70	4.885	1	TCMT 11 03 04
136.00	167.00	11	C8	3	825L-167TC11-C8	80.00	15.50	200.00	80.00	130.00	70	5.160	1	TCMT 11 03 04

Diameters gelden voor frontaal kotteren.

Voor meer informatie over trekkend kotteren raadpleegt u pagina K92

Voor meer informatie over het gebruik van slede-uitbreidingen raadpleegt u pagina K89

Ga voor kottergereedschappen, toebehoren en onderdelen naar [www.sandvik.coromant.com](http://www.sandvik.coromant.com)

Zie voor wisselplaten de Draaigereedschappencatalogus



L2



N23



N15



K89

# CoroBore® 825 gedempt fijnkottergereedschap

Coromant Capto® - inwendige koelmiddeltoevoer

KAPR  
DSGN

92°  
1

92°  
2

●●●● SilentTools®



- TCMT, TCMX, TCGT, TCGX, TCEX
- TCMW

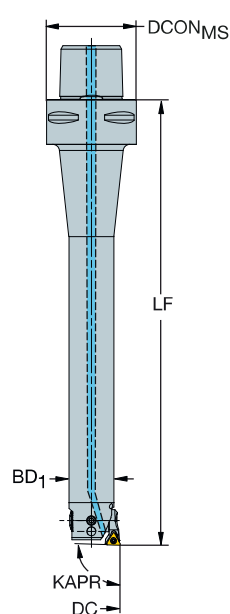
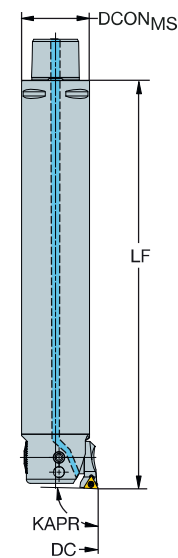

Afmetingen, mm

DCN	DCX		CZC <sub>MS</sub>	CNSC	DSGN	Bestelnummer	DCON <sub>MS</sub>	ADJLX <sub>RDL</sub>	ULDR	LF	OAH	BD <sub>1</sub>			CICT	MIID
19,00	23,00	06	C4	3	2	825D-23TC06U-C4L	40,00	2,00	6,00	163,00		18,00	70	0,568	1	TCMT 06 T1 02
23,00	29,00	06	C4	3	2	825D-29TC06U-C4L	40,00	3,00	6,00	199,00		20,00	70	0,728	1	TCMT 06 T1 02
28,00	36,00	06	C3	3	2	825D-36TC06U-C3L	32,00	4,00	6,00	216,00		25,00	70	0,968	1	TCMT 06 T1 02
35,00	45,00	09	C3	3	1	825D-45TC09U-C3L	32,00	5,00		221,00		32,00	70	1,484	1	TCMT 09 02 04
35,00	45,00	09	C4	3	2	825D-45TC09U-C4L	40,00	5,00	6,00	270,00		32,00	70	1,924	1	TCMT 09 02 04
35,00	45,00	09	C6	3	2	825D-45TC09U-C6L	63,00	5,00	6,00	297,00		32,00	70	2,574	1	TCMT 09 02 04
44,00	56,00	09	C4	3	1	825D-56TC09U-C4L	40,00	6,00		220,00		40,00	70	2,124	1	TCMT 09 02 04
44,00	56,00	09	C5	3	2	825D-56TC09U-C5L	50,00	6,00	6,00	336,00		40,00	70	3,744	1	TCMT 09 02 04
44,00	56,00	09	C6	3	2	825D-56TC09U-C6L	63,00	6,00	6,00	363,00		40,00	70	4,384	1	TCMT 09 02 04
55,00	70,00	11	C5	3	1	825D-70TC11U-C5M	50,00	7,50		300,00		50,00	70	4,940	1	TCMT 11 03 04
55,00	70,00	11	C6	3	2	825D-70TC11U-C6M	63,00	7,50	5,60	400,00		50,00	70	6,789	1	TCMT 11 03 04
69,00	87,00	11	C6	3	1	825D-87TC11U-C6M	63,00	9,00		400,00		63,00	70	9,659	1	TCMT 11 03 04
69,00	87,00	11	C8	3	2	825D-87TC11U-C8S	80,00	9,00	5,60	500,00		63,00	70	12,869	1	TCMT 11 03 04
86,00	107,00	11	C6	3	1	825D-107TC11U-C6M	63,00	10,50		400,00	64,00	80,00	70	9,729	1	TCMT 11 03 04
86,00	107,00	11	C8	3	1	825D-107TC11U-C8M	80,00	10,50		500,00		80,00	70	18,089	1	TCMT 11 03 04
86,00	107,00	11	C8	3	1	825D-107TC11U-C8S	80,00	10,50		410,00		80,00	70	15,669	1	TCMT 11 03 04
106,00	137,00	11	C6	3	1	825D-137TC11U-C6M	63,00	15,50		400,00	64,00	100,00	70	9,809	1	TCMT 11 03 04
106,00	137,00	11	C8	3	1	825D-137TC11U-C8M	80,00	15,50		500,00	81,00	100,00	70	18,199	1	TCMT 11 03 04
106,00	137,00	11	C8	3	1	825D-137TC11U-C8S	80,00	15,50		400,00	81,00	100,00	70	15,759	1	TCMT 11 03 04
136,00	167,00	11	C8	3	1	825D-167TC11U-C8S	80,00	15,50		500,00	81,00	130,00	70	18,359	1	TCMT 11 03 04

Diameters gelden voor frontaal kotteren.

Voor meer informatie over trekkend kotteren raadpleegt u pagina K92

Voor meer informatie over het gebruik van slede-uitbreidingen raadpleegt u pagina K89

Ga voor kottergereedschappen, toebehoren en onderdelen naar [www.sandvik.coromant.com](http://www.sandvik.coromant.com)

Zie voor wisselplaten de Draaigereedschappencatalogus

